

PLASTITE® 45 THREAD-FORMING FASTENER

The Plastite® 45 fastener is designed to facilitate thread-forming in less-compressible plastics while providing **high resistance to strip-out and pull-out**. It has smaller root and major diameters than a 48° Plastite, so it can be used in smaller bosses.

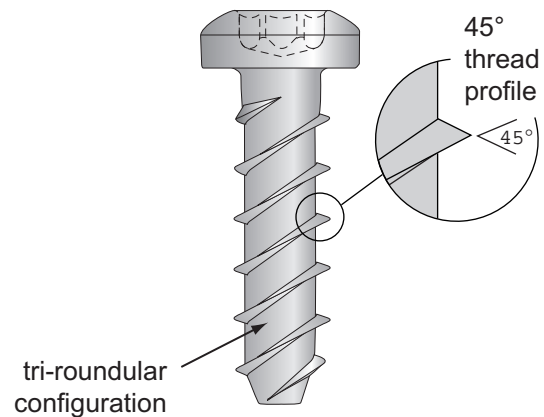

Plastite® 45 Fastener



SPECIFICATIONS

Sizes • #2 – 3/8" (metric sizes 2 – 8); other sizes may be available upon request

Head Styles • Can be used with any external or internal head designs; pan, hex washer, and flat styles standard

Drive System • Can use any system, including TORX PLUS® Drive

Finish • As required

APPLICATIONS

Engineering-grade thermoplastics (with a flexural modulus over 850,000 p.s.i.)

KEY ADVANTAGES

- Can be used in smaller bosses than Plastite 48 fasteners
- Increases product reliability
- Lowers required drive torque when fastening stiffer thermoplastics

FEATURES & BENEFITS

Tri-roundular configuration allows displaced material to cold flow back into relief areas

- Minimizes radial stress
- Reduces possibility of boss failure
- Eliminates need for inserts and lock washers
- Allows design of thinner bosses

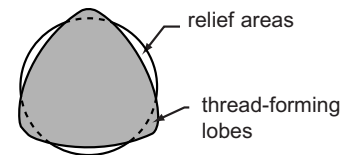

45° thread profile allows threads to penetrate deeply into plastic material

- Generates strong mating threads
- Resists vibration loosening
- Increases resistance to strip-out
- Achieves wide differentials between drive and fail torque

Single lead design and narrow helix angle lowers drive torque and failure torque in thermoplastics with a flexural modulus over 850,000 p.s.i.

- Creates less stress on the boss

PLASTITE® 45 THREAD-FORMING FASTENER

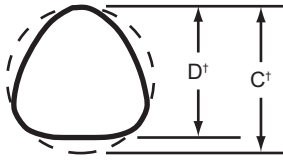

† C dimension measured with Tri-Flute Micrometer
D diameter measured with Standard Micrometer

DIMENSIONAL DATA – INCH SIZES

Nom. Size	Thread Pitch (per inch)	C Dimension max-min (in)	D Dimension max-min (in)	Screw Length Tolerance (in)	
				under 3/4"	over 3/4"
#2	19	.0875 - .0835	.0845 - .0805	± .030	±.050
#3	18	.101 - .097	.098 - .094	± .030	±.050
#4	17	.1145 - .1095	.111 - .106	± .030	±.050
#5	15	.1275 - .1225	.1235 - .1185	± .030	±.050
#6	13	.141 - .136	.137 - .132	± .030	±.050
#7	12	.153 - .148	.1485 - .1435	± .030	±.050
#8	11	.167 - .161	.162 - .156	± .030	±.050
#9	10	.179 - .173	.174 - .168	± .030	±.050
#10	9	.194 - .188	.189 - .183	± .030	±.050
#12	9	.220 - .214	.2145 - .2085	± .030	±.050
1/4"	8	.253 - .247	.247 - .241	±.050	±.050
9/32"	8	.284 - .278	.278 - .272	±.050	±.050
5/16"	8	.316 - .308	.309 - .301	±.050	±.050
21/64"	8	.332 - .324	.325 - .317	±.050	±.050
11/32"	8	.349 - .341	.342 - .334	±.050	±.050
3/8"	7	.379 - .371	.371 - .363	±.050	±.050

DIMENSIONAL DATA – METRIC SIZES

Nom. Size	Thread Pitch	C Dimension max-min (mm)	D Dimension max-min (mm)	Screw Length Tolerance (mm)	
				under 20mm	over 20mm
2	1.35	2.04 - 1.92	1.99 - .0783	±.08	±1.3
2.5	1.4	2.53 - 2.41	2.49 - 2.37	±.08	±1.3
3	1.5	3.04 - 2.92	2.99 - 2.87	±.08	±1.3
3.5	1.65	3.54 - 3.42	3.48 - 3.34	±.08	±1.3
4	1.75	4.04 - 3.89	3.94 - 3.79	±.08	±1.3
4.5	2.0	4.54 - 4.39	4.43 - 4.28	±.08	±1.3
5	2.2	5.04 - 4.89	4.94 - 4.79	±1.3	±1.3
5	2.3	5.04 - 4.89	4.94 - 4.79	±1.3	±1.3
6	2.5	6.04 - 5.89	5.93 - 5.78	±1.3	±1.3
8	3	8.04 - 7.86	7.89 - 7.71	±1.3	±1.3

PLASTITE® 45 THREAD-FORMING FASTENER

HOLE SIZES PER PERCENTAGE OF THREAD ENGAGEMENT

Inch Sizes	100% (in.)	90% (in.)	80% (in.)	70% (in.)	60% (in.)
2-19	.065	.067	.069	.071	.073
3-18	.076	.078	.081	.083	.085
4-17	.087	.090	.093	.095	.098
5-15	.099	.102	.104	.107	.110
6-13	.101	.105	.109	.112	.116
7-12	.112	.116	.120	.124	.128
8-11	.125	.129	.133	.137	.141
9-10	.131	.136	.141	.145	.150
10-9	.148	.152	.157	.161	.166
12-9	.167	.172	.177	.182	.187
1/4-8	.196	.202	.207	.213	.219
9/32-8	.221	.227	.233	.239	.245
5/16-8	.251	.257	.264	.270	.276
21/64-8	.265	.271	.278	.284	.291
11/32-8	.281	.288	.294	.301	.307
3/8-7	.302	.310	.317	.325	.332

Metric Sizes	100% (mm)	90% (mm)	80% (mm)	70% (mm)	60% (mm)
2 x 1.35	1.36	1.41	1.46	1.51	1.57
2.5 X 1.4	1.78	1.83	1.88	1.94	2.00
3 X 1.5	2.25	2.30	2.37	2.43	2.50
3.5 X 1.65	2.68	2.74	2.80	2.88	2.95
4 X 1.75	3.11	3.18	3.25	3.33	3.41
5 X 2.2	3.70	3.80	3.91	4.03	4.16
5 X 2.3	3.67	3.76	3.86	3.98	4.10
6 X 2.5	4.57	4.68	4.79	4.91	5.05
8 X 3.0	6.36	6.49	6.62	6.77	6.92

BOSS DESIGN RECOMMENDATIONS

The length of engagement (L) should be 2 to 3 times the fastener's C dimension. Testing should be done to determine optimal thread engagement on any application with a lower length of engagement.

The nominal hole size ($h\emptyset$) must be established based on the amount of thread engagement (see chart above). For optimum performance, the hole size should provide a minimum 70% thread engagement.

The outside diameter of the boss (boss O.D.) should be 2.5 to 3 times the nominal diameter of the screw (C dimension). The boss height should not exceed 2 times the boss O.D.

The counterbore width (CB_w) should be slightly larger than the C dimension. Its depth (CB_d) should be 1/4 to 1/2 the thread pitch.

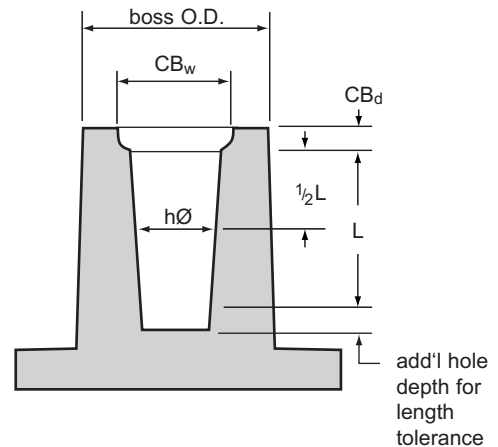

6125 Eighteen Mile Road
Sterling Heights, Michigan 48314

1.800.544.6117

acument.com

camcarsolutions.com

ringscrew.com